



H2 **W4** **A** **METAL**



GESTION DE LA CALIDAD
RI-8000-9084
GESTION SST
RI-45000-10
GESTION AMBIENTAL
RI-14000-1038



SISTEMA DE CONTENCIÓN VIAL

TVH2W4A-2

PRODUCTO

Este sistema nivel de contención liviano **H2**, ancho de trabajo **W4 (1,3 m)**, **ASI A** y deflexión dinámica de **1,2m** puede ser fabricado en **Acero Corten, Acero Galvanizado y/o Sistema Duplex** dependiendo de la zona, montado con postes C cada 2,67 metros.

PERFIL

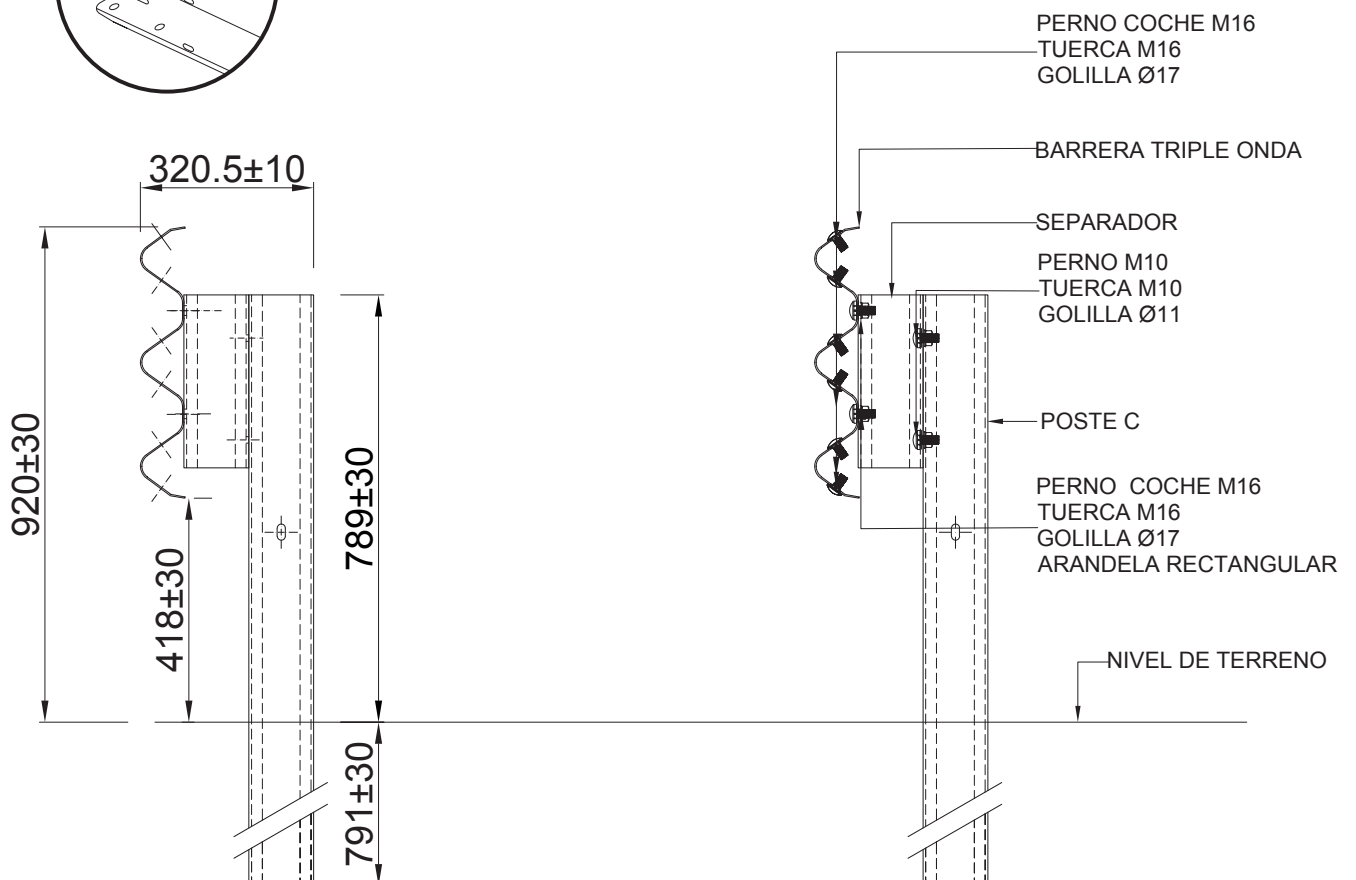
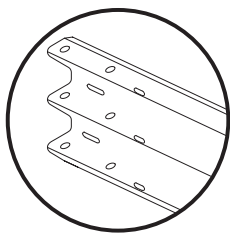



SISTEMA DE CONTENCIÓN VIAL

TVH2W4A-2

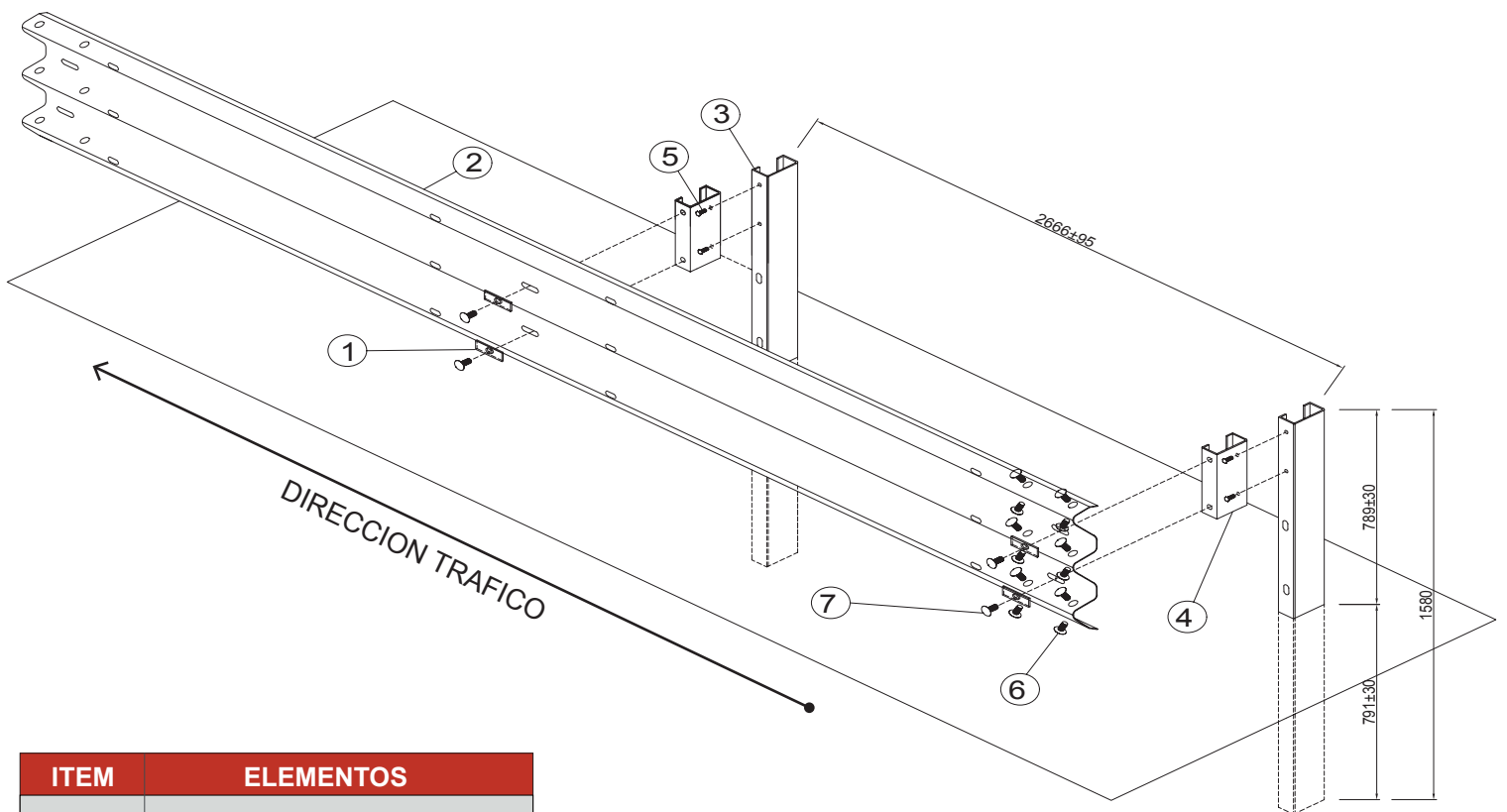

ITEM	ELEMENTOS
1	ARANDELA RECTANGULAR
2	BARRERA TRIPLE ONDA
3	POSTE C
4	SEPARADOR
5	PERNO M10
6	PERNO M16
7	PERNO M16

ESQUEMAS DE PROTECCIÓN AL ACERO

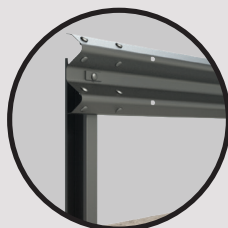

GALVANIZADO



CORTEN

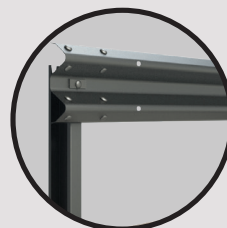

MAGNELIS



DUPLEX